

# AVERY DENNISON MARKETING SPECIFICATION

## HISTORY

THE SUBJECT MATTER DISCLOSED HEREIN EMBODIES PROPRIETARY INFORMATION WHICH IS THE CONFIDENTIAL PROPERTY OF THE AVERY DENNISON CO. NONE OF WHICH SHALL BE COPIED, REPRODUCED, DISCLOSED TO OTHERS, PUBLISHED OR USED IN WHOLE OR IN PART FOR ANY PURPOSE OTHER THAN THAT FOR WHICH IT IS BEING MADE AVAILABLE WITHOUT THE EXPRESS ADVANCE WRITTEN PERMISSION OF A DULY AUTHORIZED AGENT OF THE COMPANY. THIS DOCUMENT IS THE PROPERTY OF THE AVERY DENNISON CO. AND IS TO BE RETURNED TO THE COMPANY ON DEMAND.

REV.	DATE	DESCRIPTION
A	10/06/15	RELEASED REPLACES 20066-0

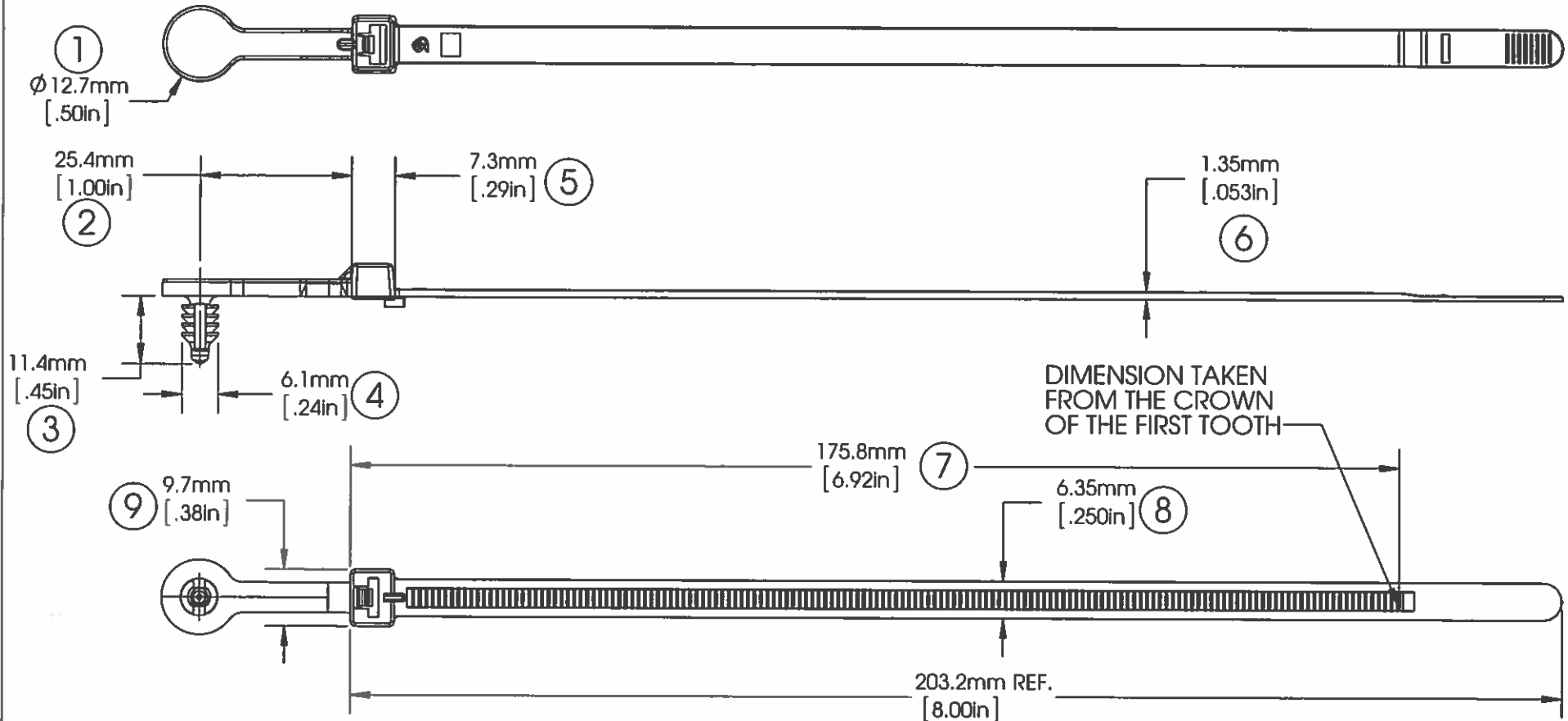

MOUNTING:	M6 THREADED HOLE
TENSILE STRENGTH:	50 LBF / 222.4N MIN.
OPERATING TEMP RANGE:	-40°F (-40°C) TO 220°F (105°C)
WEIGHT:	2.60 GRAMS EACH
BUNDLE DIAMETER:	$\phi 1/16"$ (1.6MM) TO $\phi 1-3/4"$ (44.5MM)
INSTALLATION TOOL:	12001 - HAND TOOL 12500 - PNEUMATIC TOOL
TOOL TENSION SETTING:	6 - 8
PACKAGING:	500/BAG, 10 BAGS/MASTER

<b>APPROVALS:</b>	ENG. APPR. <i>L. O. M.</i> 10/6/15 Q.A. APPR. <i>Carth &amp; J. Vallet</i> 10/6/15
-------------------	---

<b>SPECIFIED TOLERANCES</b>	<b>MATERIAL</b>
INCHES      MM	NYLON 6/6, IMPACT MODIFIED, HEAT STABILIZED
.XX ± .03      .X ± .7	<b>COLOR</b>  <b>GREY</b>
.XXX ± .01      .XX ± .25	
ANGULAR: ± 2°	

	<b>FASTENER DIVISION</b> FITCHBURG, MA 01420 U.S.A. TEL. 1-800-225-5913 FAX. 978-353-8157
<b>DESCRIPTION</b> <b>6MM OFFSET TIE, REVERSE</b>	
<b>STOCK NO.</b> <b>SPC20066</b>	<b>REV.</b> <b>A</b>